

FLEXIBLE RUBBER JOINT

Single-Sphere Flexible Rubber Joint with Floating Flanges

Fig.GFLEX-F1

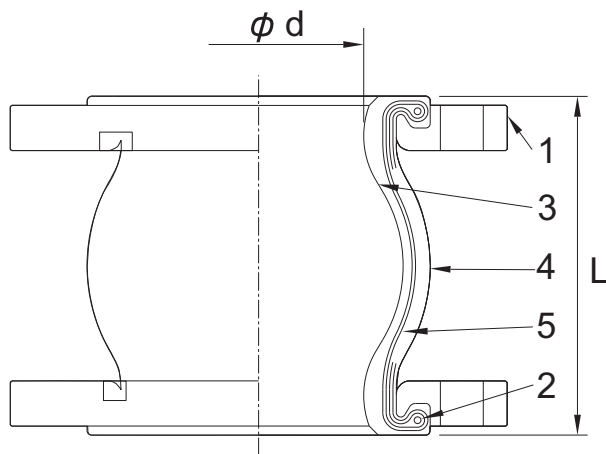

Features

Achievements

Having been used in more than 20 countries for over 30years, GALA brand products proudly demonstrate their popularity.

Reliability

Unparalleled durability is guaranteed by the distinctive and strict design standards of GALA

Quality

Manufactured in GALA's own factory under thorough control with ISO9000 quality management system.

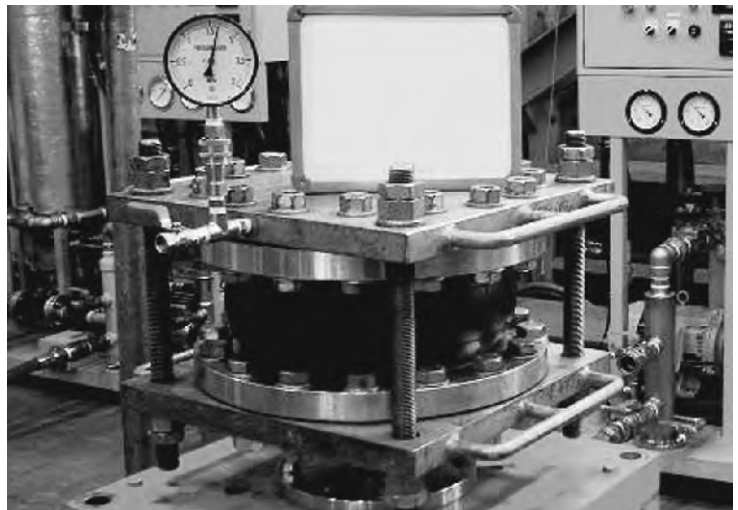

Materials

No.	Parts	Materials
1	Flange	Ductile Iron (32 - 300) Mild Steel (350-600)
2	Reinforcing Ring	Carbon Steel
3	Inner Rubber	EPDM
4	Outer Rubber	EPDM
5	Reinforcing Cord	Nylon

Flanges on ANSI, BS, etc. available.
The flange material can be changed to Mild Steel, SUS304 and SUS316. Please consult us.
JIS16K / JIS20K Flanges are all Mild steel (32~600).

FLEXIBLE RUBBER JOINT

Single-Sphere Flexible Rubber Joint with Floating Flanges

Operating Conditions and Performance

Working Temperature vs. Working Pressure

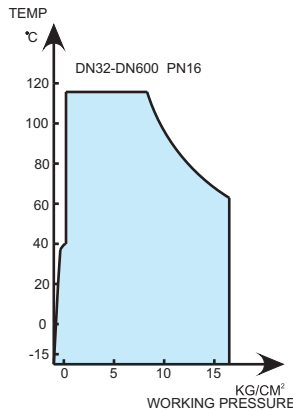

Applications

This product is mainly applicable for piping systems in commercial and industrial buildings and plants.

Applicable fluids are exclusively water including cold water, warm water, cooled water, sea water, etc.

This product can not be used for drinking water, pool water, oil, or boiled water.

Technical Parameters

Size	Working Pressure	Bursting Pressure	Vacuity
DN32-DN300	1.6Mpa	4.8Mpa	750 mmHG
DN350-DN600	1.6Mpa	4.8Mpa	500 mmHG

Dimensions and Allowable Movements

Nominal Dia. (A)		Dimensions(mm)		Mass(kg)	Allowable Movements (mm)				Installation Tolerances(mm)			
DN	inch	L	Φd		T.M.	A.E.	A.C.	A.M.(°)	T.M.	A.E.	A.C.	A.M.(°)
32	1-1/4	95	40	2.0	9	6	9	10	4	3	6	5
40	1-1/2	95	40	2.1	9	6	10	10	4	3	6	5
50	2	105	50	2.6	10	7	10	10	5	3	6	5
65	2-1/2	115	60	2.6	12	7	12	10	5	3	6	5
80	3	135	72	3.8	12	7	12	10	5	3	6	5
100	4	150	100	4.7	15	10	15	7	6	3	6	3
125	5	165	125	6.9	15	10	15	7	6	3	6	3
150	6	180	150	10	15	12	18	5	7	3	6	2
200	8	190	200	14	18	12	18	5	7	3	6	2
250	10	230	250	22	20	15	20	5	8	3	6	2
300	12	245	300	25	20	15	20	5	8	3	6	2
350	14	255	300	44	25	15	20	5	8	3	6	2
400	16	255	300	53	25	15	20	5	8	3	6	2
450	18	255	300	64.5	25	15	20	5	8	3	6	2
500	20	255	300	88	25	15	20	5	8	3	6	2
600	24	260	300	106	25	15	20	5	8	3	6	2

A.E.=Axial Elongation

T.M.=Transverse Movement

A.M.=Angular Movement

A.C.=Axial Compression

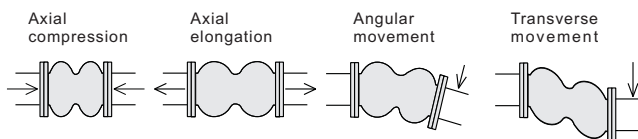

·Mass indicates only the case with JIS 10K (FCD450) flanges.

·Products should be used within the given allowable movements only.

·Tolerances for installation are included in the allowable movements (Allowable movements= Tolerances for installation+Operating movements).

·Please note that the information in the above table is for single movement only. In case of complex movements, please do adjustment by using the following formula.

$$C.A.E. (C.A.C.) = A.A.E. (A.A.C) \times \left\{ 1 - \left(\frac{T.M.}{A.T.M.} + \frac{A.M.}{A.A.M.} \right) \right\}$$

C.A.E. (C.A.C.):Correct Elongation Movement(Correct Compression Movement)
 A.A.E. (C.A.C.):Allowable Elongation Movement (Allowable Compression Movement)
 A.T.M.:Allowable Transverse Movement
 A.A.M.:Allowable Angular Movement

Example: In case of 100mm joint, if 10mm transverse movement is needed, then the correct elongation should be:

$$C.A.E. = 10 \times \left\{ 1 - \left(\frac{10}{15} + \frac{0}{7} \right) \right\} = 3.3mm$$